

# **User's Guide**

## **Agilent Technologies**

### **E1779A Battery Pack**

**This manual provides documentation for the following instruments:**

#### **Agilent ESA-E Series**

**E4401B (9 kHz- 1.5 GHz)**  
**E4402B (9 kHz - 3.0 GHz)**  
**E4404B (9 kHz - 6.7 GHz)**  
**E4405B (9 kHz - 13.2 GHz)**  
**E4407B (9 kHz - 26.5 GHz)**

#### **Agilent ESA-L Series**

**E4411B (9 kHz- 1.5 GHz)**  
**E4403B (9 kHz - 3.0 GHz)**  
**E4408B (9 kHz - 26.5 GHz)**

**and**

#### **Agilent EMC Series**

**E7401A (9 kHz- 1.5 GHz)**  
**E7402A (9 kHz - 3.0 GHz)**  
**E7403A (9 kHz - 6.7 GHz)**  
**E4405B (9 kHz - 13.2 GHz)**  
**E4407B (9 kHz - 26.5 GHz)**



**Agilent Technologies**

**Manufacturing Part Number: E1779-90014**

**Supersedes: E1779-90013**

**Printed in USA**

**December 2001**

© Copyright 1997-2001 Agilent Technologies

---

## Notice

The information contained in this document is subject to change without notice.

Agilent Technologies makes no warranty of any kind with regard to this material, including but not limited to, the implied warranties of merchantability and fitness for a particular purpose. Agilent Technologies shall not be liable for errors contained herein or for incidental or consequential damages in connection with the furnishing, performance, or use of this material.

---

## Safety Information

The following safety symbols are used throughout this manual. Familiarize yourself with the symbols and their meaning before operating this instrument.

---

### WARNING

***Warning* denotes a hazard. It calls attention to a procedure which, if not correctly performed or adhered to, could result in injury or loss of life. Do not proceed beyond a warning note until the indicated conditions are fully understood and met.**

---

### CAUTION

*Caution* denotes a hazard. It calls attention to a procedure that, if not correctly performed or adhered to, could result in damage to or destruction of the instrument. Do not proceed beyond a caution sign until the indicated conditions are fully understood and met.

---

### NOTE

*Note* calls out special information for the user's attention. It provides operational information or additional instructions of which the user should be aware.

---

## Warranty

This Agilent Technologies instrument product is warranted against defects in material and workmanship for a period of three years from date of shipment. During the warranty period, Agilent Technologies will, at its option, either repair or replace products which prove to be defective.

For warranty service or repair, this product must be returned to a service facility designated by Agilent Technologies. Buyer shall prepay shipping charges to Agilent Technologies and Agilent Technologies shall pay shipping charges to return the product to Buyer. However, Buyer shall pay all shipping charges, duties, and taxes for products returned to Agilent Technologies from another country.

Agilent Technologies warrants that its software and firmware designated by Agilent Technologies for use with an instrument will execute its programming instructions when properly installed on that instrument. Agilent Technologies does not warrant that the operation of the instrument, or software, or firmware will be uninterrupted or error-free.

---

## **LIMITATION OF WARRANTY**

The foregoing warranty shall not apply to defects resulting from improper or inadequate maintenance by Buyer, Buyer-supplied software or interfacing, unauthorized modification or misuse, operation outside of the environmental specifications for the product, or improper site preparation or maintenance.

NO OTHER WARRANTY IS EXPRESSED OR IMPLIED. AGILENT TECHNOLOGIES SPECIFICALLY DISCLAIMS THE IMPLIED WARRANTIES OF MERCHANTABILITY AND FITNESS FOR A PARTICULAR PURPOSE.

Should Agilent have a negotiated contract with the User and should any of the contract terms conflict with these terms, the contract terms shall control.

---

## **EXCLUSIVE REMEDIES**

THE REMEDIES PROVIDED HEREIN ARE BUYER'S SOLE AND EXCLUSIVE REMEDIES. AGILENT TECHNOLOGIES SHALL NOT BE LIABLE FOR ANY DIRECT, INDIRECT, SPECIAL, INCIDENTAL, OR CONSEQUENTIAL DAMAGES, WHETHER BASED ON CONTRACT, TORT, OR ANY OTHER LEGAL THEORY.

---

## **Where to Find the Latest Information**

Documentation is updated periodically. For the latest information about Agilent Technologies ESA Spectrum Analyzers or EMC Analyzers, including firmware upgrades and application information, please visit the following Internet URLs:

<http://www.agilent.com/find/esa>

<http://www.agilent.com/find/emc>

---

# Contents

<b>1. Preparing for Use</b>	
Description .....	8
Panel Description .....	8
Initial Inspection .....	9
Power Cable .....	9
<b>2. Installation and Operation</b>	
Battery Charging Procedure .....	14
Installing the Battery Pack .....	16
Installation Procedure .....	16
Operation .....	18
Basic Operation Check .....	18
<b>3. Characteristics</b>	
Characteristics .....	20
Typical Runtime .....	20
Regulatory Information .....	23
<b>4. Troubleshooting</b>	
Troubleshooting .....	26
Basic Troubleshooting .....	26
Troubleshooting the Battery Pack and the 24 Vdc Charger Power Supply .....	26
Cleaning .....	29
Replacement .....	29
<b>5. Disposal and Service</b>	
Disposal .....	32
Battery Disposal .....	32
RBRC .....	32
Contacting Agilent Technologies .....	33
Battery Pack Serial Numbers .....	33
Calling Agilent Sales and Service Offices .....	33
How to Order Parts .....	34
Direct Phone-Order System .....	34



---

# **1** **Preparing for Use**

This chapter describes the battery pack and provides initial inspection information.

---

## Description

The Agilent Technologies E1779A is a battery pack that will typically power an Agilent ESA Spectrum Analyzer or EMC Analyzer from 60 to 90 minutes, depending on the model number and the options installed in the analyzer. (See [Chapter 3, “Characteristics”](#) for more information about run time.)

## Panel Description

The battery pack has gold plated electrical contacts (1). A protective rubber safety boot (2) is attached to protect the contacts when the battery pack is not installed. A charging connector (5) is provided for attachment of the charger power supply. Adjacent to the charging connector are two LED indicator lights (4) to give visual information of the charging status. The latches (3) on each side of the battery pack are for attaching the battery pack to the analyzer. There is a hole (6) provided for the rubber safety boot plug to hold the boot in place when the battery pack is attached to the analyzer.

---

### CAUTION

The battery pack is *NOT* water resistant. It must be protected from liquids and other contaminants which could be spilled on the connector face.

---

**Figure 1-1**      **Battery Pack Description**

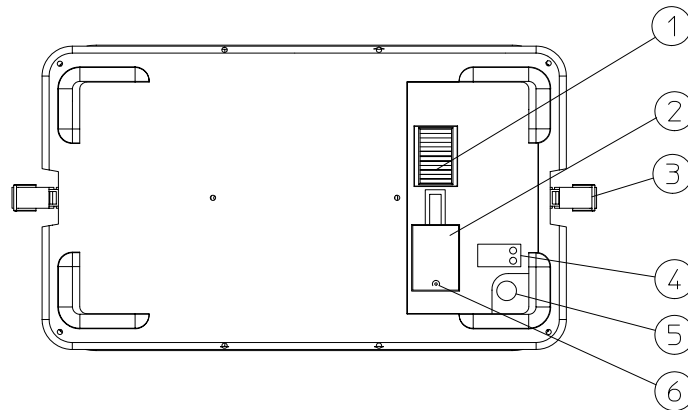

dv81a



## Initial Inspection

You should receive the following:

**Figure 1-2 E1779A Battery Pack Components**

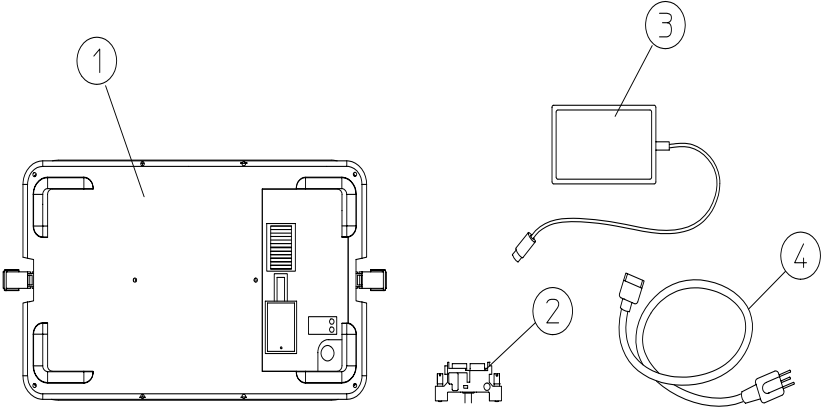

dv82a

Number	Description	Part Number
1	Battery Pack	None
2	dc Adapter	E4401-60025
3	Charger Power Supply	E1779-60002
4	ac Line Cord	See <a href="#">Figure 1-3 on page 11</a> .
	User's Guide	E1779-90013
	20 A Fuse Kit	E4401-60286

### Power Cable

The battery pack charger power supply is equipped with a three-wire power cable, in accordance with international safety standards. When connected to an appropriate power line outlet, this cable grounds the charger power supply case.

**WARNING**

**Failure to ground the charger power supply properly can result in personal injury. Insert the main power cable plug only into a socket outlet that has a protective earth contact. DO NOT defeat the earth-grounding protection by using an extension cable, power cable, or autotransformer without a protective ground conductor.**

**If you are using an autotransformer, make sure its common terminal is connected to the protective earth contact of the power source outlet socket.**

Various power cables are available to connect the charger power supply to the types of ac power outlets unique to specific geographic areas. You will receive the cable appropriate for the area to which the charger power supply is originally shipped. You can order additional ac power cables for use in different areas. The following table lists the available ac power cables, illustrates the plug configurations, and identifies the geographic area in which each cable is appropriate.





---

**CAUTION**

The battery pack should be removed when the analyzer is not being used, especially during transportation. The battery will continue to drain at a slow rate while attached to the analyzer. Over an extended period of time, the battery could discharge to the point that it irreversibly damages some of its nickel-cadmium cells, preventing the battery from being fully recharged.

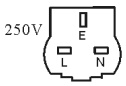
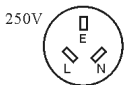
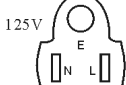
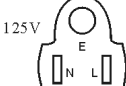
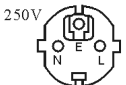
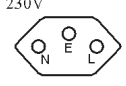
---

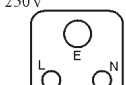
**Figure 1-3 Power Cables**

Plug Type <sup>a</sup>	Cable Part Number	Plug <sup>b</sup> Description	Length cm (in.)	Cable Color	For Use in Country
	8120-1351	Straight BS 1363A	229 (90)	Mint Gray	Option 900 United Kingdom, Hong Kong, Cyprus, Nigeria, Singapore, Zimbabwe
	8120-1703	90°	229 (90)	Mint Gray	
	8120-1369	Straight AS 3112	210 (79)	Gray	Option 901 Argentina, Australia, New Zealand, Mainland China
	8120-0696	90°	200 (78)	Gray	
	8120-1378	Straight NEMA 5-15P	203 (80)	Jade Gray	Option 903 United States, Canada, Brazil, Colombia, Mexico, Philippines, Saudi Arabia, Taiwan
	8120-1521	90°	203 (80)	Jade Gray	
	8120-4753	Straight NEMA 5-15P	229 (90)	Gray	Option 918 Japan
	8120-4754	90°	229 (90)	Gray	
	8120-1689	Straight CEE 7/VII	200 (78)	Mint Gray	Option 902 Continental Europe, Central African Republic, United Arab Republic
	8120-1692	90°	200 (78)	Mint Gray	
	8120-2104	Straight SEV Type 12	200 (78)	Gray	Option 906 Switzerland
	8120-2296	90°	200 (78)	Gray	
	8120-2956	Straight SR 107-2-D	200 (78)	Gray	Option 912 Denmark
	8120-2957	90°	200 (78)	Gray	
	8120-4211	Straight IEC 83-B1	200 (78)	Mint Gray	Option 917 South Africa, India
	8120-4600	90°	200 (78)	Mint Gray	
	8120-5182	Straight SI 32	200 (78)	Jade Gray	Option 919 Israel
	8120-5181	90°	200 (78)	Jade Gray	

a. E = earth ground, L = line, and N = neutral.

b. Plug identifier numbers describe the plug only. The HP part number is for the complete cable assembly.

plugs



---

## **2** **Installation and Operation**

This chapter provides the information needed to charge, install, and operate the Agilent E1779A battery pack.

---

## Battery Charging Procedure

---

### WARNING

**This is a Safety Class 1 Product when the battery is being charged and is provided with a protective earthing ground incorporated in the power cord. The mains plug shall only be inserted in a socket outlet provided with a protective earth contact. Any interruption of the protective conductor inside or outside of the product is likely to make the product dangerous. Intentional interruption is prohibited.**

---

### CAUTION

This product is designed for use in Installation Category II and Pollution Degree 2 per IEC 1010 and 664 respectively when being charged with the approved ac to dc supply.

Connect the ac line to the charger power supply so that the detachable power cord is readily identifiable and is easily reached by the operator. The detachable power cord is the disconnection device. It disconnects the charger power supply from the ac line. Alternatively, an externally installed switch or circuit breaker (which is readily identifiable and is easily reached by the operator) may be used as a disconnecting device.

Refer to [Figure 2-1](#).

1. Remove the battery pack (1) from the instrument.
2. Plug the charger power supply (2) into the battery pack.
3. Connect the ac line cord (3) to the charger power supply and to the ac line.

When the battery pack begins its charging cycle the red LED (5) will start flashing. The red LED will then become a solid red light. When the battery pack is fully charged, the green LED (4) will be lit.

---

### NOTE

Both LEDs will be lit if the internal temperature of the battery pack is above 55°C or below 10°C.

Continuing to charge the battery pack after the green LED is lit will not damage the unit. It will continue to charge in the trickle charge mode.

---

### CAUTION

Do not use any charger power supply other than that supplied with the battery pack.

---

### NOTE

At room temperature, it takes 6 hours to initially charge a battery, or charge a battery after it has been depleted on an analyzer while in use (battery voltage drained to ~15 VDC). Charging a fully depleted battery will take longer, possibly as long as 8 to 12 hours. Charging the battery at elevated temperatures will increase the charge time. Occasionally the battery should be fully discharged, to the depleted state, prior to charging. This will prevent degradation of battery capacity due to the memory effects exhibited by nickel cadmium batteries.

**Figure 2-1**      **Charging the Battery**

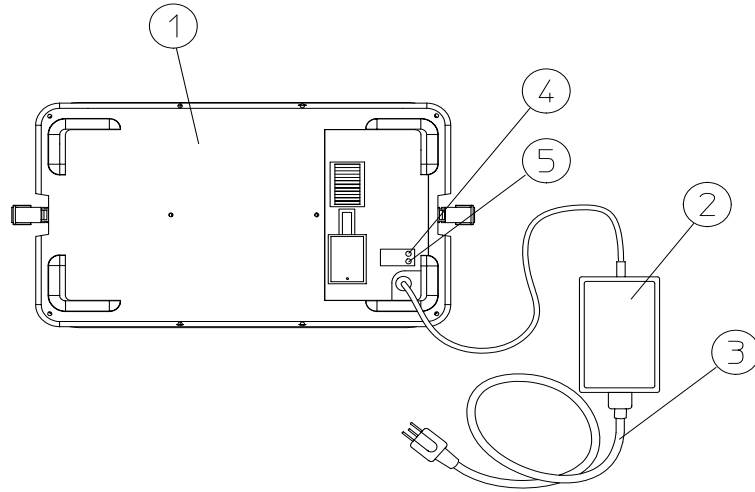

dv86a

## Installing the Battery Pack

---

**WARNING** This battery pack cannot be plugged into Agilent E4411A analyzers with a serial number of US3736xxxx or below. The mating screws are keyed to ensure that this is not possible. Overriding the keyed safety feature could be dangerous.

---

**NOTE** Analyzers with a serial number of US3736xxxx or below require the installation of Option R12 before the battery pack will operate.

---

**NOTE** Remove the analyzer ac connector (power cord) prior to installing the battery.

---

**CAUTION** Ventilation Requirements: When installing the product in a cabinet, the convection into and out of the product must not be restricted. The ambient temperature (outside the cabinet) must be less than the maximum operating temperature of the product by 4°C for every 100 watts dissipated in the cabinet.

---

There is no need to make a wire connection when installing the battery pack. The dc contacts on the battery pack press against the contacts of a dc adapter which plugs into the 12 Vdc input connector on the analyzer. The battery pack is installed by attaching the latches on each side of the battery pack to the analyzer.

Install the product according to the enclosure protection code IP 32. There is protection against the entrance of solid foreign objects that are greater than 2.5 mm in diameter and water that is dripping at an angle of less than 15 degrees.

---

**NOTE** The dc connector system is designed to ensure very little power loss so that all necessary power is supplied to the analyzer. Right angle connectors are required for rear panel connections when the battery pack is attached.

---

## Installation Procedure

Use the following procedure to install the battery pack to your analyzer:

1. Remove the power cord from the analyzer.
2. Attach the dc adapter (2) to the rear panel of the analyzer. The adapter has no polarity. Tighten the two screws.
3. Uncover the battery dc contacts by securing the safety boot in its open position.
4. Attach the battery pack (3) to the back of the analyzer. Battery pack contacts should align with the dc adapter.
5. Fasten the latches (4) on each side of the battery pack to the analyzer. Turn the analyzer on and begin dc operation.



**Figure 2-2**      **Battery Pack Installation**

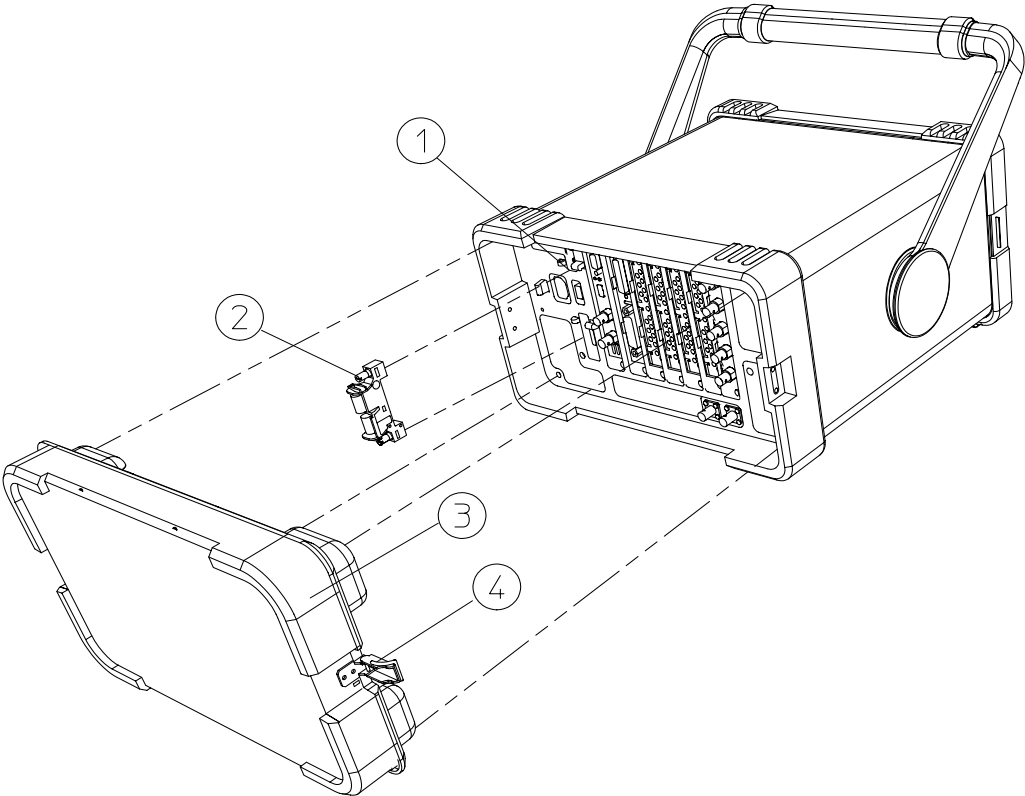

dv85a

---

## Operation

---

**WARNING**      **Shorting the battery pack contacts will result in unrepairable damage to the contacts and internal circuit. There is also the danger of burns. Use the safety boot to cover the contacts any time the battery pack is removed from the instrument.**

---

**WARNING**      **The power cord must not be installed with the battery pack in place.**

---

**WARNING**      **The charger power supply must not be connected to the battery pack when the battery pack is attached to the analyzer.**

---

An Agilent ESA Spectrum Analyzer or EMC Analyzer will operate with the same functionality on dc power as it will on ac power except that the line trigger will not function.

### Basic Operation Check

The only basic operation checks for the battery pack are whether or not it takes a charge, and whether or not the instrument powers on when the battery pack is installed.

The battery pack has no operational specifications and is therefore not subject to periodic calibration.

---

**WARNING**      **No serviceable parts inside. Do not disassemble.**

---

---

## **3** **Characteristics**

This chapter contains information about the characteristic operating parameters of the Agilent E1779A battery source. Characteristics provide useful but non-warranted information about the functions and performance of the battery pack.

---

## Characteristics

---

**NOTE** All characteristics are at 25 °C and at the beginning of battery life.

---

<b>Output Voltage</b>	19.2 volts
<b>Capacity</b>	105 watt hours
<b>Service Life</b>	500 Cycles to 80% Initial Capacity (at 25°C)

### Typical Runtime

Runtime is typically between 60 minutes and 90 minutes depending upon options installed.

<b>Chemistry</b>	Nickel Cadmium
<b>Charge Time</b>	6 Hours <sup>a</sup>
<b>Charging Temperature</b>	10°C to 40°C <sup>b</sup>
<b>Discharging Temperature</b>	0°C to 55°C <sup>b</sup>
<b>Storage Temperature</b>	-30°C to 55°C <sup>b</sup>
<b>Maximum Relative Humidity</b>	80% <sup>c</sup>

- a. Charge time may exceed 6 hours at temperatures above 25°C.
- b. Refer to the following graphs for temperature impact on battery performance and service life.
- c. For temperatures up to 31°C. Maximum relative humidity will decrease linearly to 50% at 40°C.

---

**CAUTION** Battery service life degrades rapidly at temperatures above 40°C. This effect can be minimized if it is held for only a short period of time at the high temperature, such as during discharge. Prolonged storage at only 40°C could reduce the service life to 45% of its room temperature life. The service life is reduced to 20% at 50°C.

---

**Figure 3-1 Battery Charge Capacity vs Temperature**

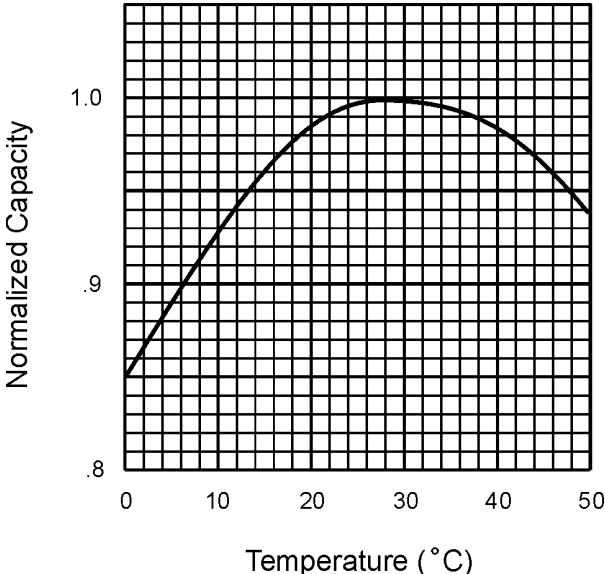

dv87a

**Figure 3-2 Battery Cycle Life vs Temperature**

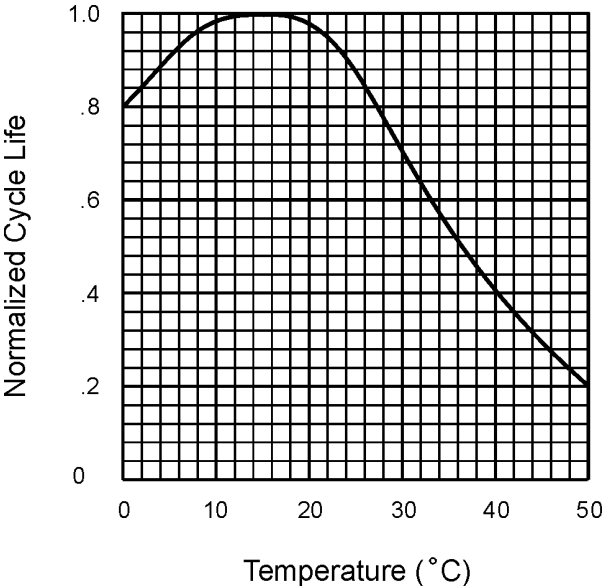

dv88a

**Figure 3-3 Battery Charge Acceptance versus Temperature**

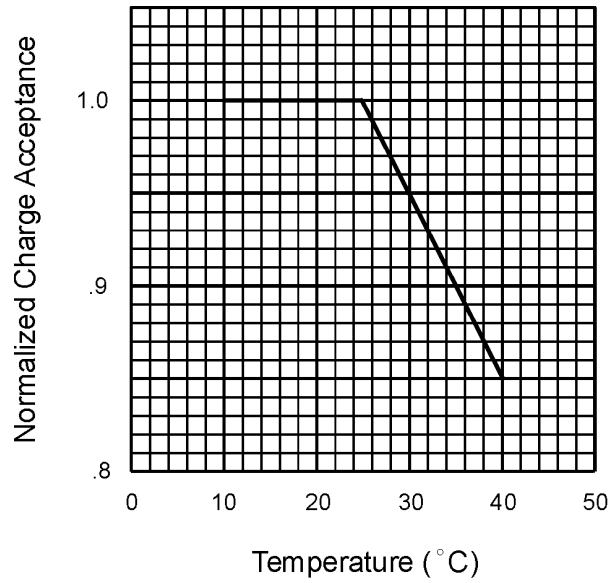

dv89a

<b>Physical Characteristics</b>	
Weight	4.8-kg (10.6-lbs)
Height	217-mm (8.54-in)
Width	373-mm (14.69-in)
Depth	68-mm (2.68-in), 44-mm (1.73-in) added to instrument depth

<b>Supply Requirements</b>	
Nominal Input Voltage	100/115/230/240 Volts
Input Voltage Range	90-254 Volts
Nominal Input Frequency	50/60 Hz
Input Frequency Range	47-66 Hz
Input Power	60 Watts Maximum
Output Voltage	24 Vdc

<b>Environmental Conditions</b>
Portable
Altitude up to 4,572 meters (15,000 feet)
This product, when being recharged with the approved ac to dc supply, is designed for use in INSTALLATION CATEGORY II and POLLUTION DEGREE 2, per IEC 1010 and 664 respectively.

---

## Regulatory Information

---

### CAUTION

This product is designed for use in Installation Category II and Pollution Degree 2 per IEC 1010 and 664 respectively.

---

### NOTE

This product has been designed and tested in accordance with IEC Publication 1010, Safety Requirements for Electronic Measuring Apparatus, and has been supplied in a safe condition. The instruction documentation contains information and warnings which must be followed by the user to ensure safe operation and to maintain the product in a safe condition.



The CE mark is a registered trademark of the European Community.



The CSA mark is the Canadian Standards Association safety mark.

**ISM 1-A**

This is a symbol of an Industrial Scientific and Medical Group 1 Class A product. (CISPR Pub. 11, Clause 4)

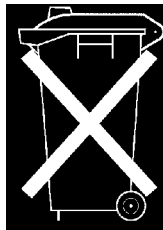

This is a symbol to alert you that you must dispose of a material properly according to your country's requirements and not just throw it into the trash.



RBRC is a trademark of the Rechargeable Battery Recycling Corporation.

## DECLARATION OF CONFORMITY

According to ISO/IEC Guide 22 and CEN/CENELEC EN 45014

**Manufacturer's Name:** Agilent Technologies, Inc.

**Manufacturer's Address:** 1400 Fountaingrove Parkway  
Santa Rosa, CA 95403-1799  
USA

Declares that the product

**Product Name:** Battery Pack

**Model Number:** E1779A

**Product Options:** This declaration covers all options of the above product.

Conforms to the following product specifications:

EMC: IEC 61326-1:1997+A1:1998 / EN 61326-1:1997+A1:1998

<u>Standard</u>	<u>Limit</u>
CISPR 11:1990 / EN 55011-1991	Group 1, Class A
IEC 61000-4-2:1995+A1998 / EN 61000-4-2:1995	4 kV CD, 8 kV AD
IEC 61000-4-3:1995 / EN 61000-4-3:1995	3 V/m, 80 - 1000 MHz
IEC 61000-4-4:1995 / EN 61000-4-4:1995	0.5 kV sig., 1 kV power
IEC 61000-4-5:1995 / EN 61000-4-5:1996	0.5 kV L-L, 1 kV L-G
IEC 61000-4-6:1996 / EN 61000-4-6:1998	3 V, 0.15 - 80 MHz
IEC 61000-4-11:1994 / EN 61000-4-11:1998	1 cycle, 100%

Safety: IEC 61010-1:1990 + A1:1992 + A2:1995 / EN 61010-1:1993 +A2:1995  
CAN/CSA-C22.2 No. 1010.1-92

### Supplementary Information:

The product herewith complies with the requirements of the Low Voltage Directive 73/23/EEC and the EMC Directive 89/336/EEC and carries the CE-marking accordingly.

This product was tested with Agilent Technologies ESA Series Spectrum Analyzers.



Santa Rosa, CA, USA 7 Oct. 2000

Greg Pfeiffer/Quality Engineering Manager

For further information, please contact your local Agilent Technologies sales office, agent or distributor.



---

## **4 Troubleshooting**

This chapter provides information on how to troubleshoot your battery pack.

## Troubleshooting

Your battery pack is built to provide dependable service during the service life of the ni-cad batteries. However, if you experience a problem, desire additional information, or wish to order parts, Agilent's worldwide sales and service organization is ready to provide the support you need.

### Basic Troubleshooting

If the battery pack does not work, follow these steps to determine the cause and resolve the problem:

1. Make sure the analyzer works with ac power. If it does not, follow the troubleshooting procedures in the analyzer user's guide.
2. If the analyzer operates on ac power, but not on dc power:
  - a. Check all of your connections. Is the dc adapter firmly in place? Are the battery contacts aligned with the dc adapter?
  - b. Check the 20 A 32 Vdc fuse on the analyzer. Replace it if it is blown. (Refer to [Figure 4-2 on page 28.](#))
3. Make sure that the battery pack is taking a charge from the charger power supply. Follow the recharging procedure. Usually batteries near the end of their life will still take a partial charge. If there is no charge at all, you may need to replace the charger power supply or the battery pack.

If you are not sure whether the cause of failure is the battery pack or the charger power supply, follow the troubleshooting procedures below, or send your battery pack and charger power supply to a service center for diagnosis. Sending both the battery pack and the charger power supply will ensure a complete analysis.

### Troubleshooting the Battery Pack and the 24 Vdc Charger Power Supply

Follow these steps to determine whether the battery pack or the charger power supply is defective:

1. Check the charger power supply for 24 Vdc  $\pm 10\%$  by measuring its voltage under load with an autoranging multimeter.

Refer to [Figure 4-1](#) when performing the following steps:

**Figure 4-1** Charger Supply Load Test Fixture

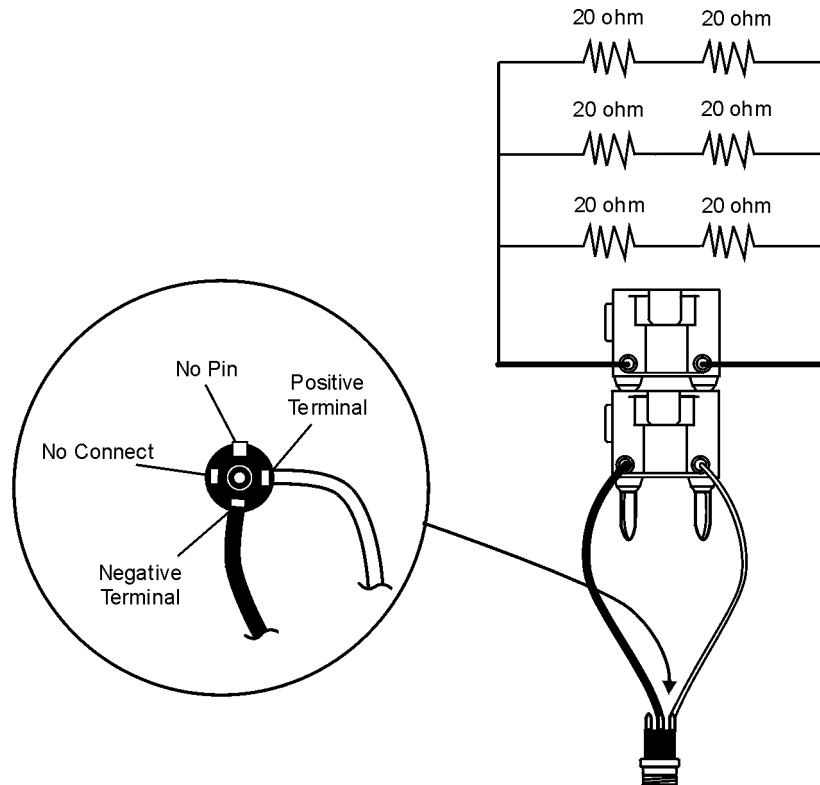

dv11a

- a. Strip the ends of two four-inch pieces of 16 AWG wire, one white and one black.
- b. Solder one end of the black wire to the negative terminal (center solder lug) of a 2.5 mm male barrel jack (part number 1252-5866), and one end of the white wire to the positive terminal (refer to [Figure 4-1](#)). Leave the third terminal of the male barrel connector unconnected.
- c. Plug the two wires from the barrel jack into the terminals of a dual banana plug (part number 1251-0005) and plug this into the multimeter.
- d. Solder together 3 pairs of 20  $\Omega$  20 W resistors (part number 0811-1656) in parallel to create the 13.3  $\Omega$  120 W equivalent circuit shown in [Figure 4-1](#).
- e. Connect this 13.3  $\Omega$  circuit to the lead terminals of a second dual banana plug and plug this into the first dual banana plug.
- f. Plug the charger power supply's barrel plug into the barrel jack.
  - If a voltage of 24 Vdc  $\pm$ 10% is not present, it indicates that the charger power supply is defective. Avoid leaving the charger power supply connected for more than 1 or 2 minutes since the resistors get very hot.

**WARNING**

**The resistors will get very hot. Handle with care.**

2. If the correct charger power supply voltage (24 Vdc  $\pm$ 10 %) is present, plug the charger power supply into the battery pack and ensure that the red LED flashes, then remains on.

---

**NOTE**

The red LED should turn on and the battery should charge initially even if the battery pack is fully charged.

If the green LED turns on immediately, this indicates a defective battery pack. If the red LED continues blinking, this indicates that the battery pack voltage is below 16 Vdc. The battery will charge in trickle mode until this condition no longer exists. If this condition continues longer than 24 hours, this also indicates a defective battery pack.

3. If the red LED flashed and then remained on, as expected, confirm that the battery charges correctly by probing the battery pack contacts with the multimeter. The charger power supply will start charging the battery initially even if the battery is fully charged. The voltage should gradually increase, indicating that the battery is charging. If the voltage does not increase by several hundredths of a volt over a period of 1 to 2 minutes, this indicates that the battery is not charging properly. You may wish to retry the test by unplugging and then plugging in the charger power supply again. If the battery still does not charge, unplug the charger power supply and replace it with a known good charger power supply and repeat the test. If the battery charges, this indicates that the original charger power supply is defective. If the battery does not charge with a new charger power supply, this indicates that the battery pack is defective.

---

**NOTE**

Both LEDs will be lit if the internal temperature of the battery pack is above 55°C or below 10°C.

4. If all three of these tests pass, it indicates that the charger power supply and the battery pack are both working.

---

**NOTE**

Defective battery packs should be discarded according to individual country's requirements.

**Figure 4-2**

**DC Adapter Plug and Fuse**

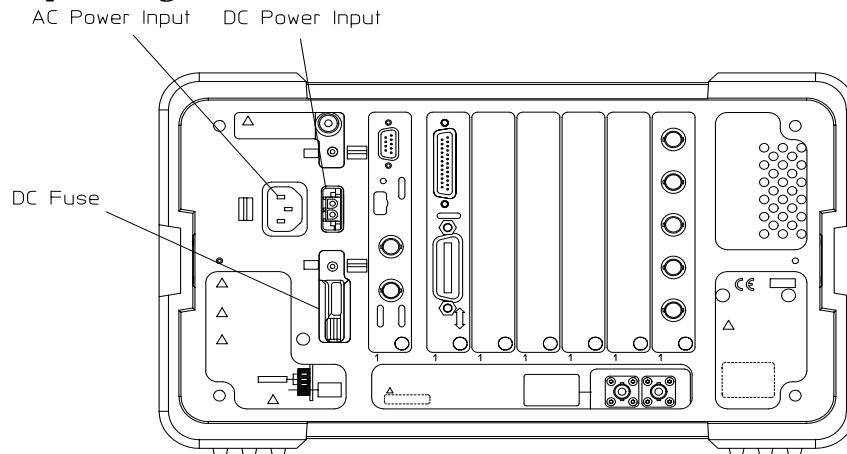

dv810a

## Cleaning

The battery pack contacts will provide good service over the life of the assembly. Should they become contaminated, clean by wiping gently with a clean dry cloth.

## Replacement

When run time is unacceptable, replace the battery pack. The battery pack cannot be opened for repair. The only replaceable parts are the charger power supply, the dc adapter, the power cord, and the safety boot.

### Latch Replacement

If the latch (1) to the battery pack needs to be replaced, order part number 1390-1061. Remove the two screws (part number 0515-0433) holding the latch in place, and attach the new latch.

### Safety Boot Replacement

To replace the safety boot (2), order part number E4401-40022 from Agilent. Cut the remaining parts of the old safety boot from the battery pack. Insert the feet of the new safety boot into the holes provided.

**Figure 4-3**

### Replaceable Parts

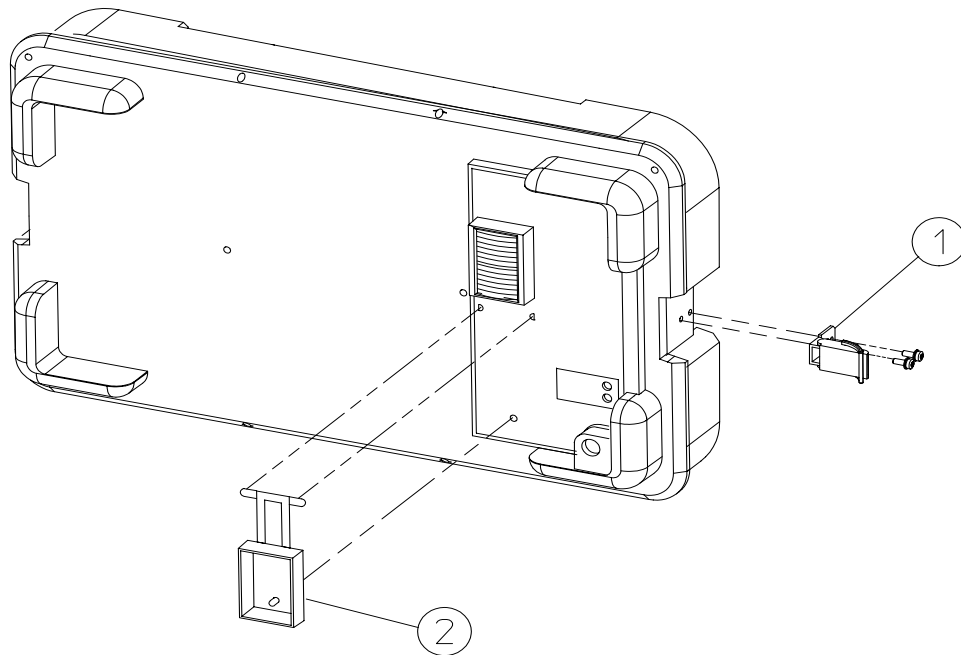

dv83a



---

## **5 Disposal and Service**

This chapter provides information on disposing of your battery pack when its service life is gone, and on contacting Agilent Technologies for service.

---

## Disposal

### Battery Disposal

When the batteries are exhausted and/or ready for disposal, dispose of them according to your country's requirements. Within the US, you may contact RBRC for disposal.

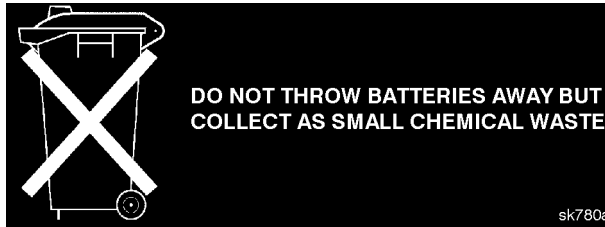

### RBRC

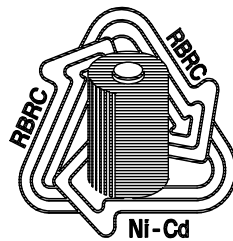

dv84a

The RBRC Seal on the nickel-cadmium battery pack indicates that Agilent Technologies is voluntarily participating in an industry program to collect and recycle these battery packs at the end of their useful life, when taken out of service within the United States. The RBRC program provides a convenient alternative to placing spent nickel-cadmium battery packs into the trash or municipal waste stream, which is illegal in some areas.

Agilent's arrangement with RBRC makes it easy for you to drop off your spent battery pack at local retailers of replacement nickel-cadmium batteries, or authorized Agilent product service centers. You may contact your local recycling center for information on where to return the spent battery pack. Please call 1-800-BATTERY for information on NiCD battery recycling in your area. Agilent's involvement in this program is part of its commitment to protecting our environment and conserving natural resources.

RBRC is a trademark of the Rechargeable Battery Recycling Corporation.



---

## Contacting Agilent Technologies

If you have a problem with your battery pack, check the troubleshooting steps earlier in [Chapter 4, “Troubleshooting,”](#) or return the battery pack to Agilent.

### Battery Pack Serial Numbers

Agilent makes frequent improvements to its products to enhance performance, usability, or reliability. Our service personnel have access to complete records of design changes to each type of product, based on the serial number and option designation.

Whenever you contact Agilent Technologies about your battery pack, have the complete serial number available. This will ensure that you obtain accurate service information.

The serial number label is attached near the dc output connector on the battery pack.

The serial number has two parts: the prefix (two letters and the first four numbers), and the suffix (the last four numbers). Refer to [Figure 5-1](#).

**Figure 5-1** Example Serial Number



The two letters identify the country in which the battery pack was manufactured. The four numbers of the prefix are a code identifying the date of the last major design change incorporated into the battery pack. The four digit suffix is a sequential number, and coupled with the prefix, provides a unique identification for each battery pack produced. Whenever you list the serial number or refer to it in obtaining information about the battery pack, be sure to use the complete number, including the full prefix and suffix.

### Calling Agilent Sales and Service Offices

Agilent's sales and service offices are located around the world to provide complete support for your battery pack. To obtain servicing information or to order replacement parts, contact the nearest Agilent Sales and Service office listed in [Table 5-1](#). In any correspondence or telephone conversations, refer to the battery pack by its model number and full serial number. With this information, the representative can quickly determine whether your battery pack is still within its warranty period.

## How to Order Parts

To order an assembly or part, quote the Agilent part number and indicate the quantity required.

If you do not have the part number, include the following information with the order:

- Model number
- Serial number
- Description of where the part is located, what it looks like, and its function (if known).
- Quantity

Parts can be ordered by addressing the order to the nearest Agilent office. Customers within the USA can also use either the direct mail-order system, or the direct phone-order system described below. The direct phone-order system has a toll-free phone number available.

## Direct Phone-Order System

Within the USA, Agilent can supply parts through a direct mail-order system. Advantages of using the system are as follows:

- Direct ordering and shipment from Agilent.
- No maximum or minimum on any mail order. (There is a minimum order amount for parts ordered through a local office when the orders require billing and invoicing.)
- Prepaid transportation. (There is a small handling charge for each order.)
- No invoices.

To provide these advantages, a check or money order must accompany each order. Mail-order forms and specific ordering information are available through your local Agilent office.

By internet, phone, or fax, get assistance with all your test and measurement needs.

**Table 5-1 Agilent Sales and Services Offices**

**Online assistance:** [www.agilent.com/find/assist](http://www.agilent.com/find/assist)

**United States**  
(tel) 1 800 452 4844

**Japan**  
(tel) (+81) 426 56 7832  
(fax) (+81) 426 56 7840

**New Zealand**  
(tel) 0 800 738 378  
(fax) (+64) 4 495 8950

**Europe**  
(tel) (+31) 20 547 2323  
(fax) (+31) 20 547 2390

**Canada**  
(tel) 1 877 894 4414  
(fax) (905) 282 6495

**Latin America**  
(tel) (305) 269 7500  
(fax) (305) 269 7599

**Australia**  
(tel) 1 800 629 485  
(fax) (+61) 3 9210 5947

**Asia Call Center Numbers**

Country	Phone Number	Fax Number
Singapore	1-800-375-8100	(65) 836-0252
Malaysia	1-800-828-848	1-800-801664
Philippines	(632) 8426802 1-800-16510170 (PLDT Subscriber Only)	(632) 8426809 1-800-16510288 (PLDT Subscriber Only)
Thailand	(088) 226-008 (outside Bangkok) (662) 661-3999 (within Bangkok)	(66) 1-661-3714
Hong Kong	800-930-871	(852) 2506 9233
Taiwan	0800-047-866	(886) 2 25456723
People's Republic of China	800-810-0189 (preferred) 10800-650-0021	10800-650-0121
India	1-600-11-2929	000-800-650-1101

